

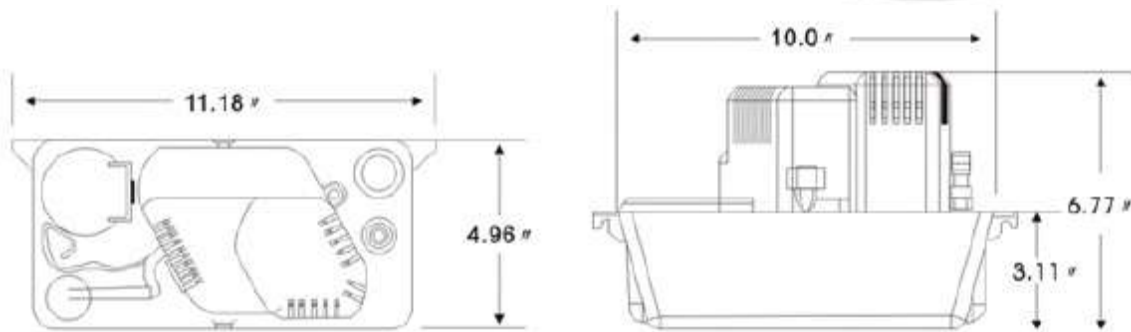

CONDENSATE PUMP

Haile condensate removal pumps are designed for air conditioners, furnaces, refrigeration, drinking fountains, beverage machines, dehumidifiers and other water removal.

- 6 foot cord with plug
- Vertical type pump unit
- 2 drainage holes
- Simple installation
- Thermal overload protection
- Quiet operation
- Switch float mechanism
- High impact ABS tank



HL CP12 SERIES

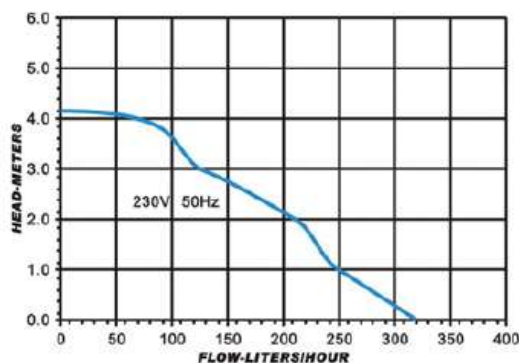

SPECIFICATIONS:

Item No	Model No	Discharge Size	Approval	HP	Volts	Hertz	Amps	Watts	Performance(L/H@Head)					Shut off Ft.	Cord Length (ft.)	Safety Switch	6M Tubing
									1	2	3	4	4.2				
883611	HL-CP12	3/8" OD Barbed	CE	1/50	230V	50	0.75	65	250	210	125	50	0	4.2	6	No	No
883612	HL-CP12	3/8" OD Barbed	CE	1/50	230V	50	0.75	65	250	210	125	50	0	4.2	6	Yes	No
883613	HL-CP12	3/8" OD Barbed	CE	1/50	230V	50	0.75	65	250	210	125	50	0	4.2	6	Yes	Yes