

A	B	C	D
380 mm	350 mm	225 mm	320 mm

GENERAL INFO

DESIGNED FOR MAINS WATER

Reverse Osmosis Drinking Water System

When only the purest water will do, conveniently on tap. The latest in Reverse Osmosis, a filtration process for high purity water. The ultra-fine membrane operates by rejecting impurities and flushing them out to drain.

This system effectively eliminates 98% of all dissolved impurities, heavy metals, salts, viruses, bacteria, cysts, fluoride, nitrate, chlorine, taste, odour, and chemicals. Only pure, sparkling clear water from your own water supply is left for your health, safety and peace of mind.

SPECIFICATIONS

MODEL:	R0270
Maximum Flow:	270 litres per day
Cartridges	
Taste & Odour Removal:	MC051
Taste & Odour Removal:	CB951
Membrane:	RET1812-75
Min/Max Temperature:	0 - 30°C
Min/Max Pressure:	300 - 875 kPa
Maximum Inlet TDS:	2,000 mg/L
Maximum Hardness:	171 mg/L - (10 grain)
Connection:	½" compression tee
Required hole for the tap:	13 mm diameter
Warranty:	3 years[^]

Important Note: Use only genuine Puretec replacement cartridge. [^]3 year warranty iss 1 year parts & labour, plus 2 years parts only.

FEATURES & BENEFITS

- 0.0005 micron rating for 98% removal of impurities.
- Fluoride & Nitrate removal.
- No bacteria build-up through integrated flushing.
- Improves taste, odour and appearance. Pure, safe water at your fingertips.
- Simple installation kit including holding tank.
- ¼" turn ceramic disc faucet with LED reminder light.
- Most advanced and most highly effective purification process.
- Very convenient and no power required.
- Has minimum care and servicing.
- Low production costs, gives you water of a guaranteed quality for less than 2 cents per litre per day.

R0270 REVERSE OSMOSIS FILTRATION TECHNOLOGY

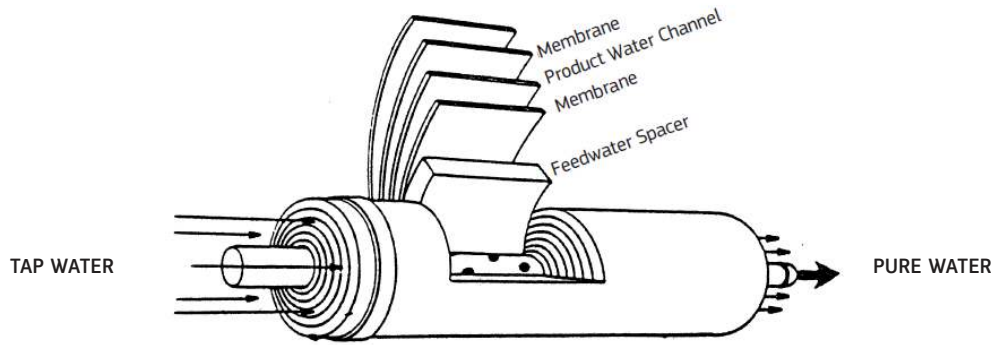

Polluted water is forced by mains water pressure against a semi-permeable membrane. Purified water molecules easily pass through the membrane while pollutants, typically being larger than the pores, cannot pass through and are washed away.

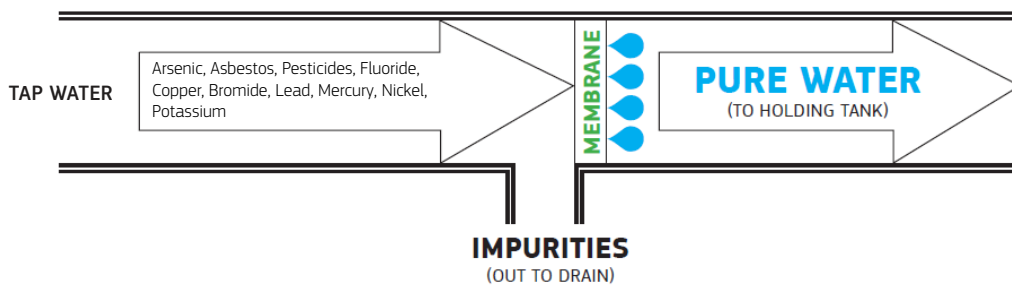

BACTERIA VS VIRUS SIZE COMPARISON

Comparative sizes of the bacteria & virus to the typical ro membrane pores

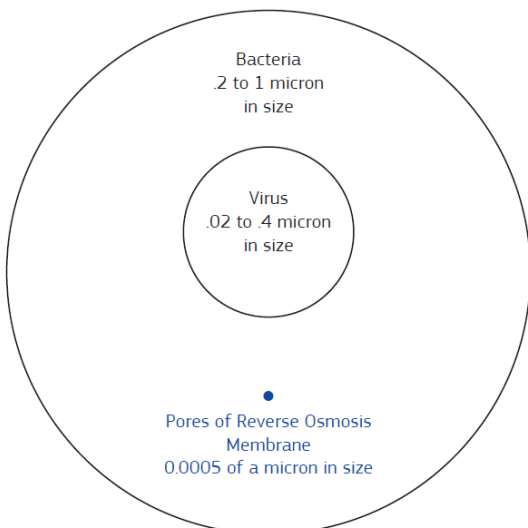

RO SYSTEM REJECTION VS THE NET WATER PRESSURE

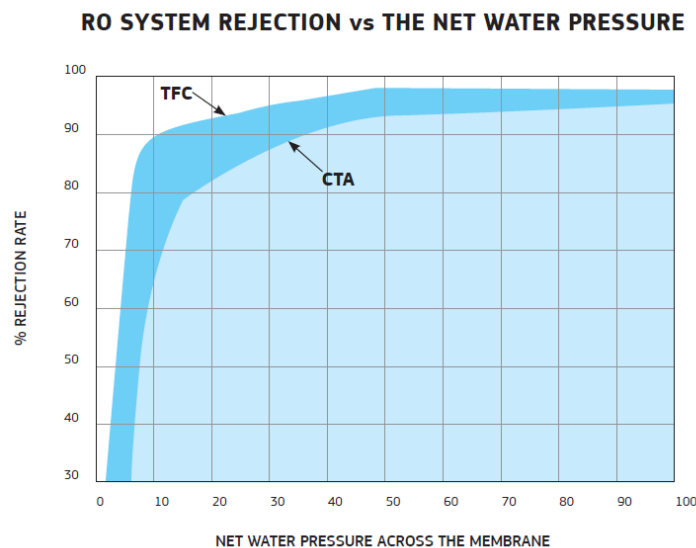

REJECTION RATES FOR MEMBRANES

Below are typical average rejection rates for the Thin Film membrane. All results are averaged from tests performed on water at 60 psig and 77°F. NOTE: TF membranes should not be exposed to oxidizers such as chlorine.

CATION REJECTION RATES

NAME	SYMBOL	PERCENT REJECTION
Aluminum	Al ⁺³	80-92
Ammonium	NH ₄ ⁺¹	94-98
Barium	Ba ⁺²	96-98
Cadmium	Cd ⁺²	87-94
Calcium	Ca ⁺²	95-98
Trivalent Chromium	Cr ⁺²	95-97
Hexavalent Chromium	Cr ⁺⁵	96-98
Copper	Cu ⁺²	86-92
Total Hardness	Cat ⁺² and Mg ⁺²	98-99
Ferrous Iron	Fe ⁺²	98-99
Lead	Pb ⁺²	98-99
Manganese	Mn ⁺²	96-99
Magnesium	Mg ⁺²	94-98
Mercury	Hg ⁺²	96-98
Nickel	Ni ⁺²	93-96
Potassium	K ⁺¹	96-98
Silver	Ag ⁺¹	96-98
Sodium	Na ⁺¹	96-98
Strontium	Sr ⁺²	96-98
Zinc	Zn ⁺²	98-99

ANION REJECTION RATES

NAME	SYMBOL	PERCENT REJECTION
Arsenate	AsO ₄ ⁻³	80-95
Arsenite	AsO ₂ ⁻¹	60-70
Bicarbonate	HCO ₃ ⁻¹	90-96
Borate	B ₄ O ₅ (OH) ₄ ⁻²	30-70*
Bromide	Br ⁻¹	94-96
Chloride	Cl ⁻¹	90-95
Chromate	CrO ⁻²	90-98
Cyanide	CN ⁻¹	90-95*
Ferrocyanide	Fe(CN) ₆ ⁻⁴	99+
Fluoride	F ⁻¹	90-96
Nitrate	NO ₃ ⁻¹	60-90*
Phosphate	PO ₄ ⁻³	99+
Selenate	SeO ₄ ⁻²	94-97
Selenite	SeO ₃ ⁻²	94-97
Silicate	SiO ₄ ⁻⁴	95-97
Sulfate	SO ₄ ⁻²	99+
Sulfite	SO ₃ ⁻²	98-99
Thiosulfate	S ₂ O ₃ ⁻²	99+

ORGANIC REJECTION RATES

NAME	PERCENT REJECTION
Acetic Acid	50
Asbestos	99.9
Bacteria & Virus	99.9+
Cyst & Turbidity	99.9
Detergents	99
Dyes	99.9
Formaldehyde	20
Glucose	99.9
Lactose Sugar	99.9
Organic Pesticides	99
Phenol	50
Protein	99.9
Pyrogen	99.9
Sucrose Sugar	99.9
Urea	40-60

*Bacteria growth through the membrane may occur in time. Organics are also reduced at a comparable rate by carbon adsorption.

LIMITATIONS FOR TF MEMBRANES

TDS ppm maximum level	2000
pH Range	3-11
Pressure Range	35 psi-1 00 psi
Water Supply	0-1 0 gpg hardness 0-.5 ppm iron
Temperature Range	Temperature Range 35°F-1 00°F
Urea	40-60

NOTE: Recommended hardness for extended product life is zero gpg hardness and zero ppm iron.